



Effect of change of material on Piston used for automotive application

¹Priyanka Guru(OIST, Indore), ²Amit BahekarHOD ME (OIST, Indore)

Abstract

As Automotive industry is showing its interest in improving its technology day by day. Keeping this scenario in mind a comparative study is performed on the piston using two different materials so as to find the results of performance of piston after changing its material. For this static structural and thermal analysis is performed on an automotive piston using two different materials i.e. structural steel and Graphite. Graphite which is very light in weight as compared to other metals is chosen as the material for the piston as it is well known that it act as a self-lubricating material and can give better results when implemented with different components of engine. After this Static Structural and Thermal analysis is performed on both the pistons by using ANSYS 14.5 Software. The effect of new material on the Static and thermal behaviour of piston as compared to graphite and structural steel piston is observed.



The main objective of this study is to check the variations in stresses and thermal behaviour when replacing the piston material with of graphite material. Also to determine the reduction in weight with the use of Graphite piston.

Keywords: - SI engine piston Static structural analysis, steady state thermal analysis, CATIA V5, ANSYS.

INTRODUCTION

Engine being the most important component of the power train of the vehicle and supplies energy to the different components after converting it into various forms. Engine consists of various mechanisms and components induced in it for different functioning. Piston is one of them which is connected to the cam shaft is responsible for all the strokes in an engine which includes intake, Compression, Expansion and exhaust. Piston of IC engine is used in today's industry is basically made up of Al-alloy. It is also a moving component that is contained by the cylinder. The main purpose of piston is to transfer force which is generated by the expanding gas to crankshaft through the connecting rod. The fatigue failure occurs in the piston by the effect of cyclic gas pressure and the inertia forces. Piston head is kept at a highest stress concentration Main reason for the fatigue failure is stress concentration.

In the thermal analysis the properties of material are studied with the change in temperature where as in static structural analysis stresses are calculated at certain static loading condition. For both the static structural and thermal analysis Finite element method is use.



The efficiency of IC engine is greatly depended on design of piston as well as the material which is used in piston. The piston with the less weight is more efficient than the conventional one. In this study analysis is done on the piston with Graphite and Structural steel.

PISTON DESIGN

The piston is designed according to the procedure and specification, given in Machine Design & design data hand book. The entire dimensions are in SI units. The parameters which are taken into consideration are following,

Pressure on piston head, temperature, heat flow, stresses, strain, diameter of piston, length of piston etc.

A. Design Consideration For a Piston

- (1) Piston should have enough strength to withstand the high pressure.
- (2) Piston should form proper oil sealing in the cylinder.
- (3) Piston should have reciprocation speed high without making noise.
- (4) For preventing undue wear, piston should provide sufficient bearing area.

B. Design procedure for piston

- (1) Mechanical efficiency
- (2) Indicated power
- (3) Thickness of piston head
- (4) Piston rings
- (5) Width of top land & ring land
- (6) Piston barrel
- (7) Length of skirt
- (8) Length of piston pin
- (9) Piston pin diameter
- (10) Heat flow through piston head

$$(1) \eta_{\text{mech}} = \frac{BP}{IP}$$

$$IP = \frac{BP}{0.8} = \frac{5.5}{0.8} = 6.875 \text{ KW}$$

Where: η = Mechanical efficiency

IP = Indicated Power

BP = Break power



$$(2) IP = \frac{P \times L \times A \times n}{60}$$

$$P_{me} = 1.244 \text{ MPa}$$

$$P_{max} = 10 \times P = 12.44 \text{ MPa}$$

Where: P= pressure in MPa
 L= Length of piston in mm
 A= Area of piston in mm²

(3) Thickness of piston head

$$t_H = D \sqrt{\frac{3 P_{max}}{16 \sigma t}}$$

$$t_H = 9.28$$

empirical formula

$$t_n = 0.032D + 1.5 = 3.19 \text{ mm}$$

$$[M_f = 45.493 \text{ kg/kws}]$$

$$\left[t_n = \frac{[C \times HCV \times m \times BP] \times 10^6}{12.56 \times 150 \times 75 \times 3600} \right]$$

(4) Piston rings:-

(i) Radial thickness

$$t_1 = D \sqrt{\frac{3 P_w}{\sigma t}}$$

$$P_w = 0.025-0.042 \text{ N/mm}^2$$

$\sigma = 85-110 \text{ MPa}$ for cast iron rings

$$t_1 = 1.688 \text{ mm}$$

(ii) Axial Thickness

$$t_2 = 0.7 t_{1 \text{ tot} 2} = (0.7 \times 1.688) = 1.181 \text{ mm}$$

Where: D = Diameter of Bore in mm

(5) Width of top land and Ring land

(i) Width of top land

$$b_1 = t_H \text{ to } 1.2 t_H = 8.018 \text{ mm}$$

Width of ring land



$$b_2 = 0.75 t_1 \text{ to } t_2 = 1.266\text{mm}$$

(6) Piston Barrel

- (i) Thickness of piston Barrel at top end

$$t_3 = 0.03 D + b + 4.5\text{mm}$$

$$t_3 = 0.03 \times 53 + 2.088 + 4.5 = 8.178\text{mm}$$

- (ii) Thickness of piston Barrel at open end

$$t_4 = (0.25 t_3 \text{ to } 0.35 t_3) = 2.022 \text{ mm}$$

(7) Length of skirt

$$L_s = (0.6 D \text{ to } 0.8 D) = 31.8\text{mm}$$

(8) Length of piston pin in on rod bushing

$$l_1 = 45\% \text{ of piston dia.} = 23.85$$

(9) Piston pin dia.

$$d_p = (0.28 D + 0.038 D)$$

$$= 14.9\text{mm}$$

Centre of pin should be 0.02 D to 0.04 D above piston skirt

- Heat flow through piston head

$$H = 12.56 \times t_H \times (T_c - T_E) \text{ KJ/sec}$$

$$H = 744.368 \text{ KJ/sec}$$

Where: T_c = temperature at the center of piston head in °C

T_E = temperature at the edges of the piston head in °C



Calculated parameters for piston

S. NO.	Parameter	Size in mm
1	Length of piston	42
2	Cylinder Bore	53
3	Axial thickness of ring	1.181
4	Radial thickness of ring	1.688
5	Maximum thickness of barrel	8.178
6	Width of the outer ring land	1.266
7	Width of the top land	8.018
8	Length of skirt	31.8
9	Piston pin Diameter	15.9

Modeling & Analysis

Modeling of Piston is done using CATIA V5. CATIA V5 is uses for specialized work of 3D model. The final product file is converted to .stp for importing in ANSYS then analysis is done.

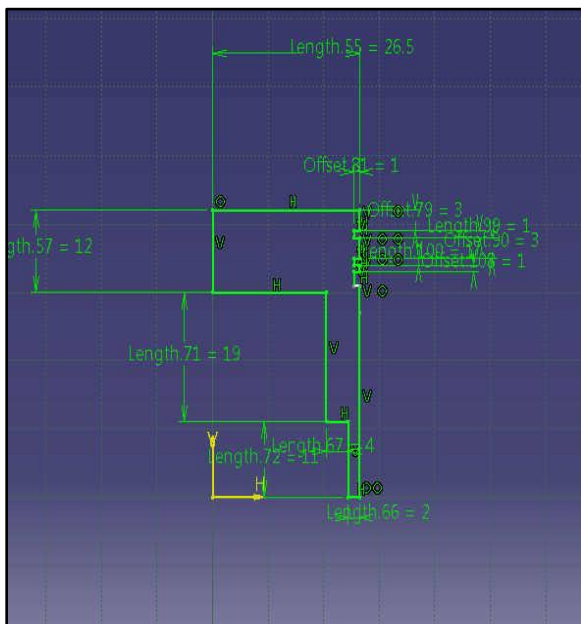
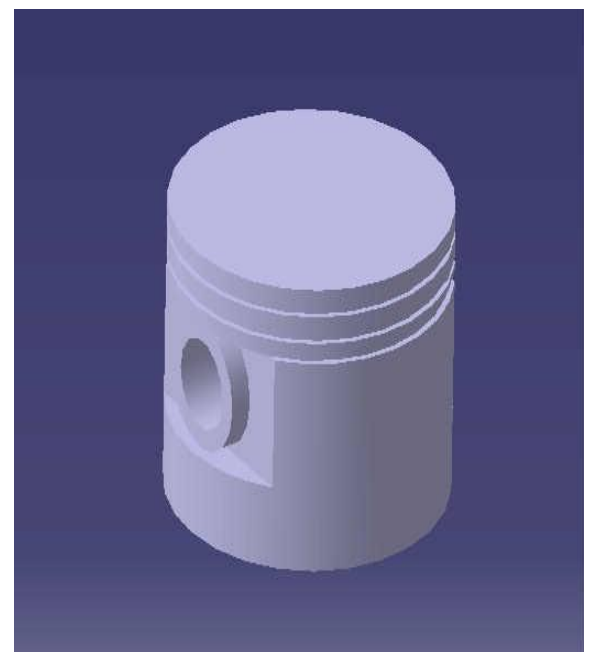

Fig: 1 Catia V5 Section of piston

Fig:2 Catia V5 3D Model of piston





ANSYS

ANSYS is a multi-Physics computing software falls under the category of CAE i.e. Computer Aided engineering analysis software used for providing the approximate solutions to the problems.

In other word its main purpose is to perform finite element Analysis for finding the approximate numerical solutions of Mechanical problems. Finite element analysis basically refers to dividing the component or the part into finite number of elements. For analysis of piston ANSYS 14.5 is used.

Modeling of piston is done in CATIA V5 R20 software and it is imported in ANSYS 14.5 for further analysis.

Methodology, Boundary and loading Conditions

After the 3D modeling of piston by using CATIA V5 the procedure for the analysis of the 3D modal is following,

- 1-Firstly generating the Computer model
- 2-Assign the property of material for component
3. Applying boundary conditions.
4. Applying load 12440N.
5. Mesh generation.
6. Solving for obtaining results.
7. Creating the job to get output data file.

Thermal & Geometric Properties Of Piston Material

For controlling the thermal stresses and deformation, it is more important to calculate the piston temperature distribution. Approximately 50% of power loss is generated by the piston ring. If the clearance which is filled by the lubricating oil has a small value, because of which the frictional losses increases.

Material Properties Of Piston Material



S.NO.	Property	Structural steel	Graphite
1	Poisson Ratio	0.33	0.23
2	Young's Modulus	2E+11	2.76E+10
3	Thermal conductivity	60.5	24
4	Co efficient of thermal Expansion	1.2E-05	1.2E+06

In most of the IC Engine thermal expansion co efficient of piston material is 80% higher than the cylinder bore material.

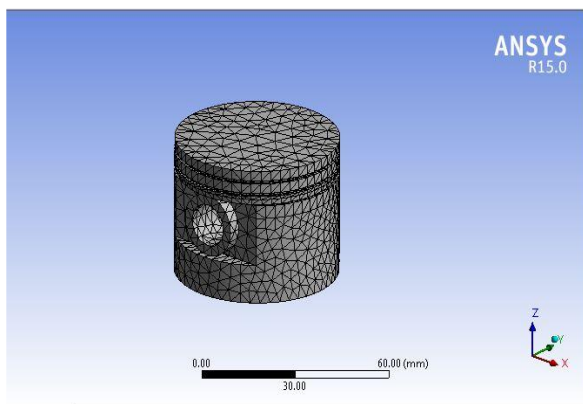

Meshing of Piston with tetrahedron mesh

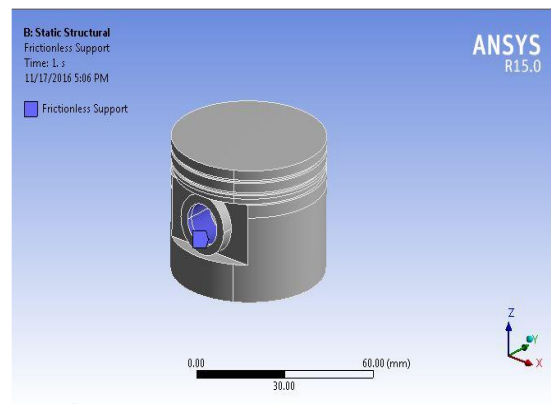

Frictionless support on gudgeon pin

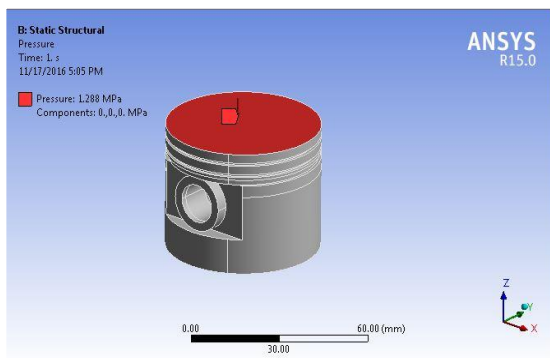

Pressure Load On Piston

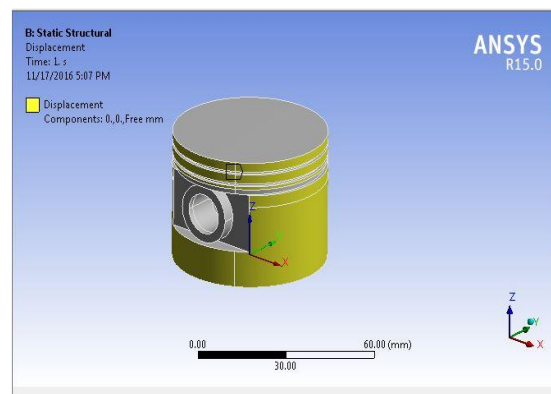

Displacement of piston constrained in Zdirection



Procedure Explained:

After assigning the Material to the model in ANSYS Workbench Meshing of component is done taking the tetrahedron mesh of element size 1 mm resulting in 8466Elements and 15212Nodes. Then after meshing Suitable boundary conditions are assigned in the ANSYS Workbench following the working Principles of Piston i.e. Load (Pressure of 12.44MPa) is applied on the piston head, Frictionless support is provided on the gudgeon pin on both side, And the boundary condition for the displacement in only Z direction is assigned keeping the displacement in X and Y axis constantly Zero.

Result and Discussion of Static Structural Analysis

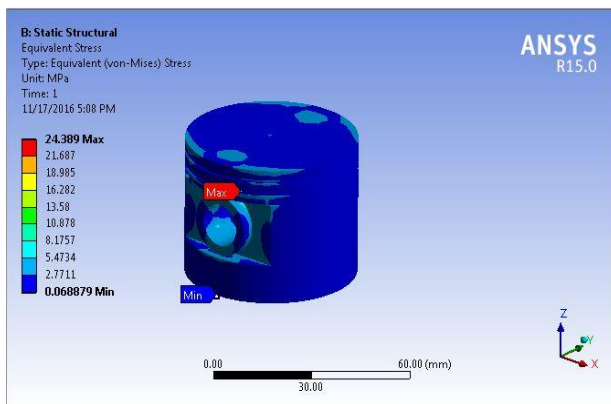

Von mises stress for graphite piston

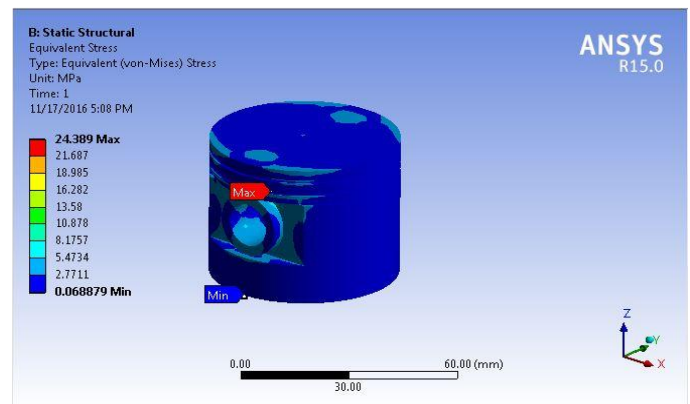

Von mises for structural steel

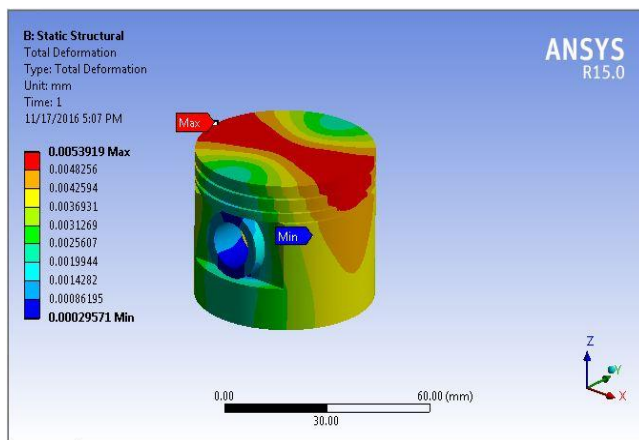

Total deformation for graphite piston

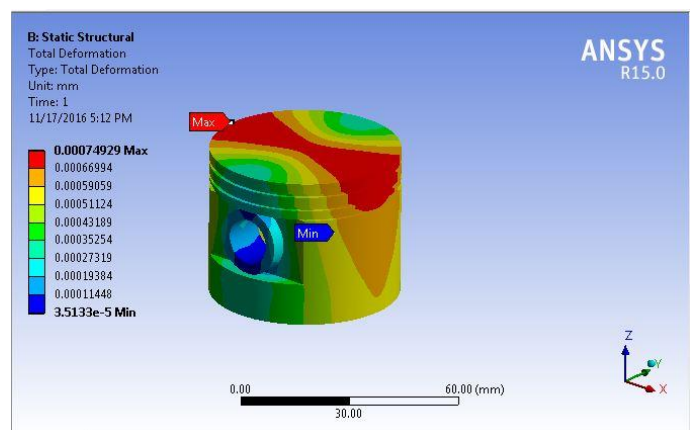

Total deformation for structural steel piston



After assigning the Boundary conditions results for Von-mises stress and deformation are calculated for Graphite piston and structural steel. On performing the analysis Max. Equivalent stress for graphite 24.389 and for structural steel is 24.428 MPa. In the same manner results were calculated for total deformation also in which max. Deformation for graphite piston is 0.0053919 mm and for structural steel is 0.00074929 mm

Methodology, Loading and Boundary Conditions for Steady State Thermal Analysis:

After the 3D modelling of piston by using CATIA V5 the procedure for the analysis of the 3D modal is following,

1. Firstly Importing the CAD model
2. Assign the property of material for component
3. Applying boundary conditions
4. Mesh generation
5. Solving for obtaining results
6. Creating the job to get output data file

MATERIAL PROPERTIES OF PISTON MATERIAL

With reference to the static structural analysis same material properties are applied on the component in steady state thermal analysis also

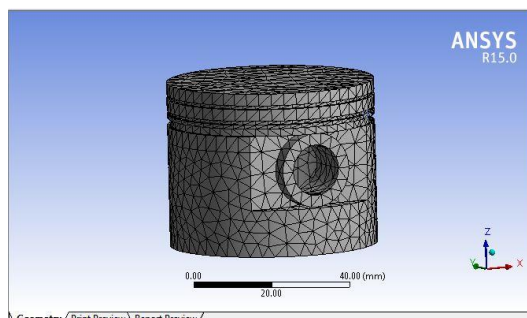

Meshing of piston with Triangular element

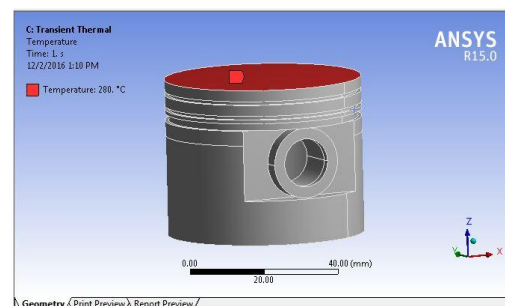

Temperature applied on piston head

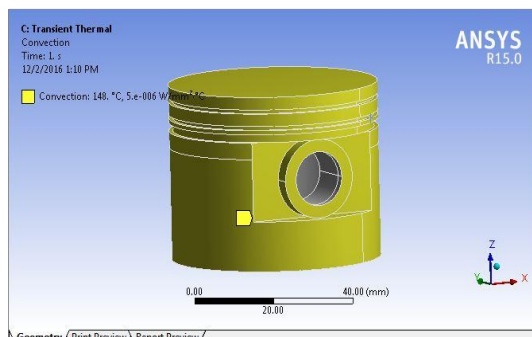

Convection applied on piston side wall

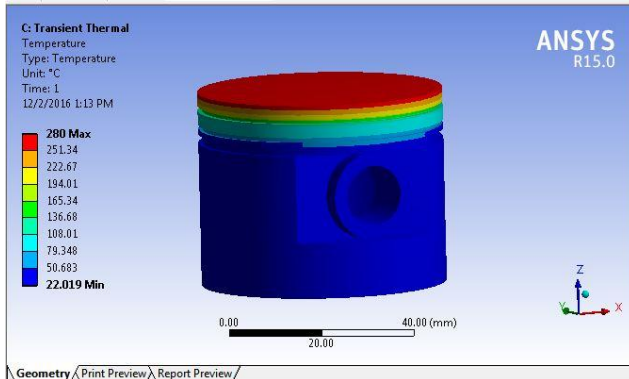

Max. Temperature for graphite piston

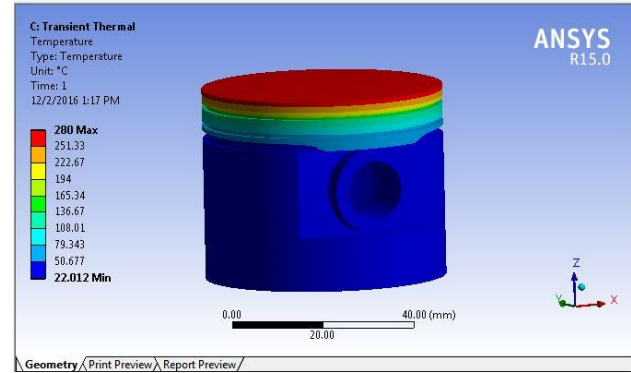

Max. Temperature for structural steel piston

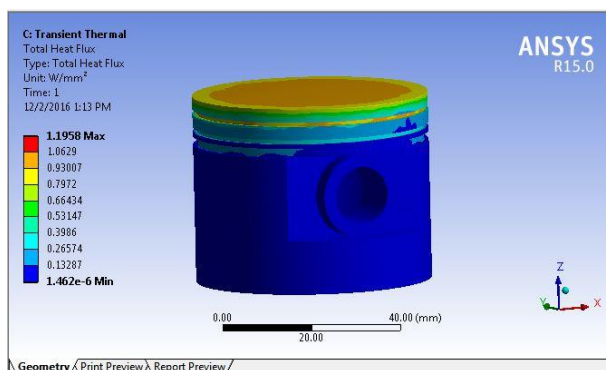

Max. Heat flux for Graphite piston

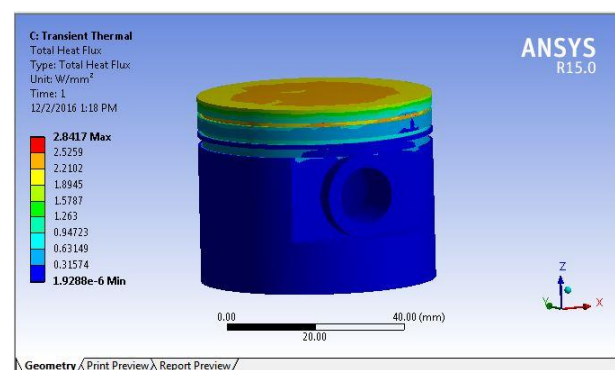

Max.heat flux for structural steel

After assigning the Boundary conditions results for Max. Temperature and Max. Heat Flux is calculated for graphite piston and structural steel Piston. On performing the analysis Max. Temperature Value ranges from 22.019 to 280°C for graphite piston and for structural steel it ranges from 22.012°C to 280°C. In the same manner results were calculated for total heat Flux also in which Max. Heat Flux for graphite piston was 1.462 W/mm and for structural steel was 1.9288 W/mm.

CONCLUSION

From the Above Results of Static Structural and Steady State Thermal Analysis it is concluded that the graphite piston shows outstanding results in both the analysis procedures with the additional weight Reduction of 70% and is a good indication to replace the structural steel Piston with graphite piston in Automotive Industry.

References:

1. B.R. Ramesh and KishanNaik, ” -Thermal Stress Analysis of Diesel Engine Piston”
2. Ajay Raj Singh, Dr Pushendra Kumar Sharma, -Design, Analysis and Optimization of Three Aluminium Piston Alloys Using FEA, Ajay Raj Singh et al Int. Journal of Engineering Research and Applications



3. Dallwoo Kim, Akemi Ito, Yasuhiro Ishikawa, Katsuyuki Osawa, Yoshiyuki Iwasaki- Friction Characteristics of Steel Pistons for Diesel Engines
4. A.R. Bhagat, Y. M. Jibhakate, Kedar Chimote- Thermal Analysis and Optimization Of I.C. Engine Piston Using Finite Element Method
5. Bedajangam S. K., N. P. Jadhav- Friction Losses between Piston Ring-Liner Assembly of Engine Internal Combustion Engine, International Journal of Scientific and Research Publications.
6. James A McGeehan - Effects of Piston and Ring Friction and lubricating oil viscosity on fuel economy.
7. John Staffan - Experimental Investigation of Partial Laser Surface Texturing on Piston Rings for Reduction of Friction of a Four Stroke Single Cylinder Si Engine Fuelled With CNG.
8. G. Ryk & I. Etsion- Testing piston rings with partial surface texturing for friction reduction, wear.
9. G. Ryk, Y. Kligerman & I. Etsion- Effect of inertia forces, squeeze film action and pressure boundary conditions on the friction force between a Laser textured piston ring and cylinder liner surfaces.
10. E. Share & I. Etsion- The effect of partially laser surface textured piston rings on the fuel consumption and exhaust gas composition of a compression-ignition I.C. engine.