

Effect of four wave mixing in WDM optical transmission system

Rajesh Mishra¹, N.K.Shukla² and C.K.Dwivedi³

Department of Electronics & Communication University of Allahabad, India

Email: rajeshmishra26@yahoo.co.in

Abstract: Crosstalk due to Four Wave Mixing is the dominant nonlinear effect in long haul multichannel optical communication system which can severely limit system performance. The paper describes the performance analysis of FWM on bit error rate, Q factor, output spectrum and eye opening by varying channel spacing and number of channels. The result shows that the FWM effect reduces with increase in channel spacing and decreases in number of channels. The reduction is more effective for unequal channel spacing than equal channel spacing.

Keywords: Four wave mixing, wavelength division multiplexing, bit error rate.

I. Introduction

Very high capacity, long haul optical communication system are made possible by the extremely wide bandwidth of optical fibers which is best exploited by wavelength division multiplexing (WDM) (Agarwal, 2002). Optical fibers in telecommunication systems now carry more channels and higher optical powers than ever before. Systems are operating in which the fiber carries such a high optical power density that signals can modify the transmission properties of the fiber. An optical channel can then affect how it and other channels propagate through the fiber leading to nonlinear effects. By the term nonlinear, we mean that the optical signal leaving the fiber at a given wavelength no longer increases linearly with the input power at that wavelength.

In order to meet the huge capacity demands imposed on the core transmission network by the explosive growth in data communications the number of optical channels in dense-WDM optical networks is being increased. Since the gain bandwidth of



© JRPS International Journal for Research, Publication & Seminar

EDFAs is limited, these requirements for a very large number of channels mean that the channel spacing will have to be small. The current ITU grid specifies 100 GHz channel spacing, but systems are being considered with 50 GHz to 25GHz channel spacing. At these spacing, the nonlinear effects of the optical fiber can induce serious system impairments. Four-Wave-Mixing (FWM) is another nonlinear effect that can limit the performance of WDM systems [1].

When high power optical signal is launched into a fiber Linearity, optical response is lost. Four-wave mixing is due to changes in the refractive index with optical mixing power called optical Kerr effect. Four-wave mixing (FWM) is a parametric process in which different frequencies interact and by frequency mixing generate new spectral components. When new frequencies fall in the transmission window of original frequency it causes severe cross talk between channels propagating through an optical fiber. Degradation becomes very severe for large number of WDM channels with small spacing. In this paper, we have simulated the effect of FWM products in WDM environment by varying the channel spacing and number of channels.

II. FOUR WAVE MIXING

Four-wave mixing (FWM) is a type of optical Kerr effect, and occurs when light of two or more different wavelengths is launched into a fiber. Fig.1 is a schematic diagram that shows four-wave mixing in the frequency domain. As can be seen, the light that was there from



before launching, sandwiching the two pumping waves in the frequency domain, is called the probe light (or signal light). The idler frequency f_{idler} may then be determined by

$$f_{idler} = f_{p1} + f_{p2} - f_{probe} \quad (1)$$

Where, f_{p1} and f_{p2} are the pumping light frequencies, and f_{probe} is the frequency of the probe light [3]. This condition is called the frequency phase matching condition.

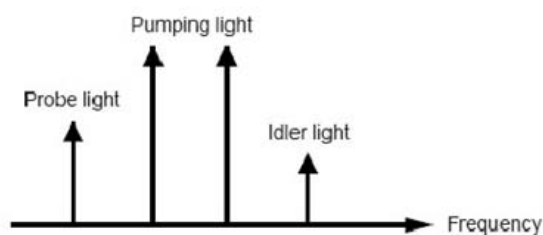

Fig. 1 : Two channel pump wave

FWM can have important deleterious effects in optical fiber communications, particularly in the context of wavelength division multiplexing where it can cause cross-talk between different wavelength channels, and/or an imbalance of channel powers[4]. FWM can transfer data to a different wavelength. A continuous wave pump beam is launched into the fiber together with the signal channel. Its wavelength is chosen half-way from the desired shift. FWM transfers the data from signal to the idler beam at the new wavelength [5, 7, 9].

Applications of FWM:

- i. Parametric amplification.
- ii. Optical phase conjugation.
- iii. De-multiplexing of OTDM channels.
- iv. Wavelength conversion of WDM channels.
- v. Super-continuum generation.

Four-wave mixing (FWM) (also called four photon mixing) is one of the major limiting factors in WDM optical fiber communication systems that use the low dispersion fiber or narrow channel spacing. Normally, multiple optical channels passing through the same fiber interact with each other very weakly. In the FWM effect, three co-propagating waves produce nine new

optical sideband waves at different frequencies. When this new frequency falls in the transmission window of the original frequencies, it causes severe cross talk between the channels propagating through an optical fiber.

The number of the side bands due to the FWM increases geometrically, as shown in Fig.2.

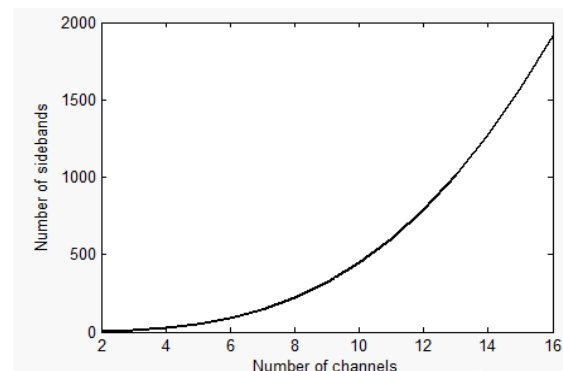

Fig. 2: Number of FWM sideband

III. SCHEMATIC MODEL

The transmitter section consists of a laser, modulator driver, pn-sequence generator i.e. data source and modulator. The wavelength of various channels is set by keeping the difference equal to the spacing required. Then all these transmitted signals are combined/multiplexed together. Then the combined signal is amplified so that it can be transmitted over long distances without its degradation. Then the signal is transmitted over the nonlinear fiber which adds the nonlinearities into the signal. At the receiver side, the signal is de-multiplexed. The receiver consists of a photodiode and a filter.

IV. SIMULATION AND DESCRIPTION

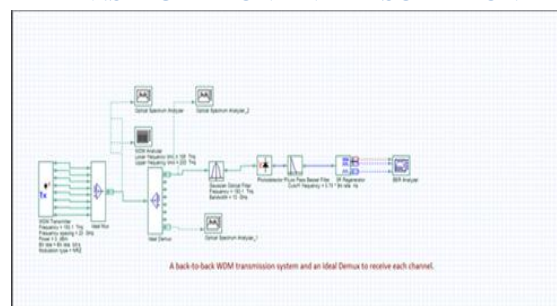

Fig. 3: Schematic model for WDM system



The simulation setup for showing the effect of changing spacing between the input channels on fourwave mixing is shown in Fig 3. The continuous wave laser is used to create the carrier signal. In this setup, eight users are taken in account whose wavelengths have a specific difference i.e. spacing between them. The data source is used to generate the random input data bit sequence at the rate of 10 Gbps. The light signal modulates the input data. The modulator is driven by the modulator driver which decides the input data format. The input data format used here is NRZ raised cosine. The modulated data from all the users is combined using a Ideal Mux. The post amplifier amplifies the signal before allowing it to enter into the fiber to avoid losses. Then this signal is sent over the fiber. At the receiver, the signal is demultiplexed by using Ideal Demux which splits this signal into the same number of signals as were transmitted. The photodiode is used for optical to electrical conversion. Then the signal is passed through the Raised cosine filter and the final output signal is received. An optical scope is attached at the output of Ideal Mux to examine the input signal. Another optical scope is placed at the output of Ideal Demux to examine the four wave mixing effect in frequency spectrum. An electrical scope is kept at the receiver output to examine the eye diagram. Initially the four wave mixing effect has been compared for different values of channel spacing and the performance has been evaluated in terms of output spectrums, eye diagrams, BER, eye opening and Q-factor. Here, all the channels are spaced evenly but at different values like 20 GHz, 30GHz, 50GHz, 70 GHz, 75 GHz, 90GHz and 95GHz.

Also FWM effect is analyzed for unequal channel spacing and by varying the number of channels in WDM system.

V. RESULTS AND DISCUSSION

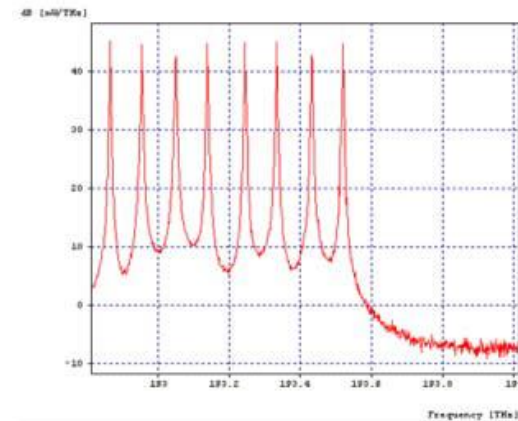

Fig. 4a: Input Pattern for 95 GHz channel spacing

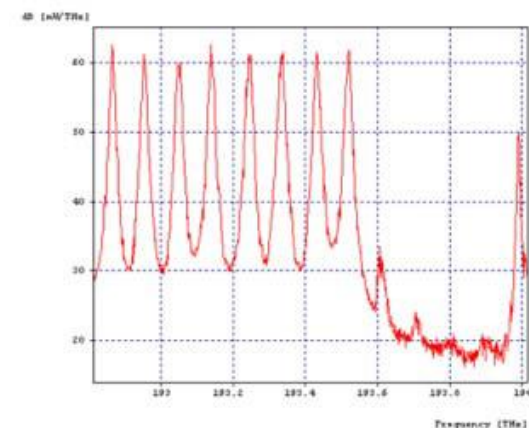

Fig. 4b: Output Pattern for 95 GHz channel spacing

Using simulation setup, the value of BER, Q-factor, eye diagrams, input and output optical spectrum are measured. Optical scope measures the input and output wavelength spectrums. BER, eye diagrams and Q-factor is measured at the receiver output by using an electrical scope, Q estimator and BER estimator.

Fig.4a shows the input and optical spectrum for the spacing of 95 GHz between input channels. On changing the spacing between the different users, the peaks get shifted to the frequencies as specified in the laser. It is observed that there are no unnecessary side peaks at the input of the fiber. There are eight input channels so eight peaks appear in the input spectrum. Fig.4b represents the output spectrum for the spacing of 95 GHz between input channels. The four wave mixing effect is clearly seen in the above output spectrum for 95 GHz spacing as unnecessary peaks at various frequencies are occurring at the sides



of the input spectrum. Moreover, the peaks at the input frequencies have also diminished due to four wave mixing occurred after crossing the nonlinear fiber.

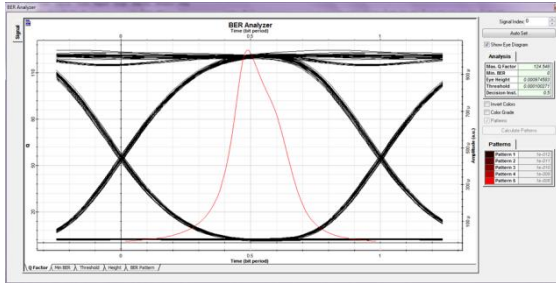

Fig. 5a: Q-factor for 95 GHz channel spacing

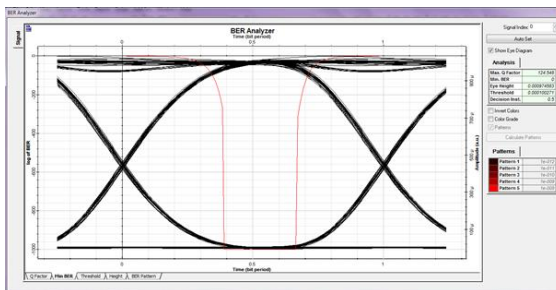

Fig. 5b: Min. BER for 95 GHz channel spacing

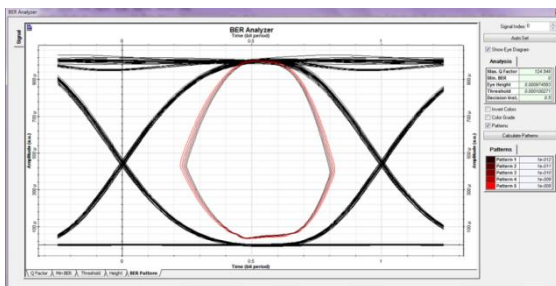

Fig. 5c: Eye Pattern for 95 GHz channel spacing

The above spectrums shows that as the spacing between the input channels increases, the four wave mixing effect goes on decreasing. The unwanted peaks are more when the spacing is 20GHz and are less when the spacing is 95GHz. This shows that lesser the spacing between different input channels, more is the interference between the input frequencies i.e. more is the four wave mixing effect. On increasing the spacing between the input channels, the four wave mixing decreases.

Fig.5a, Fig.5b and Fig.5c shows the Q- factor, Min. BER and Eye diagrams for the 95 GHz channel spacing. The above eye diagrams show that the eye diagram clarity goes on increasing with the increasing spacing between the input channels. This shows that the interference between the input frequencies and hence the four wave mixing effect decreases with the increasing channel spacing. Fig 6 shows the variation of BER on the basis of spacing between the input channels. The Fig shows that BER goes on decreasing with the increasing spacing.

Fig 7 shows the variation of Q-factor with the spacing between the input channels. The graph shows that the Q-factor increases as the channel spacing increases. It is highest when the channel spacing is 95 GHz and is lowest when the channel spacing is 20 GHz.

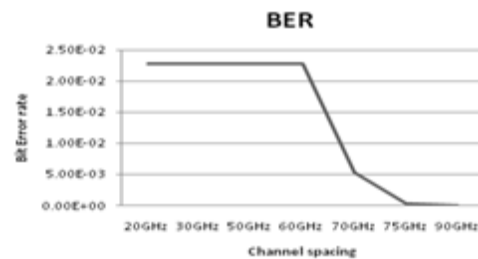

Fig.6 : BER factor Vs channel spacing

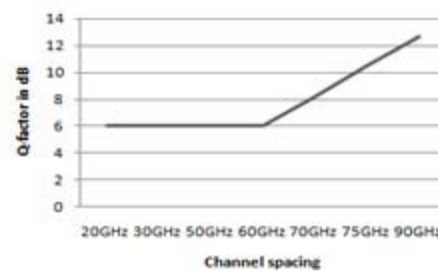

Fig.7:

BER factor Vs channel spacing

In a WDM system if channels are equally spaced, the new waves generated by FWM will fall at channel frequencies and thus will give rise to crosstalk. Hence we have change the channel spacing and for three different cases Q factor and BER is measured as shown in Fig. 8 and Fig 9 As discussed earlier, FWM effect increases as number of channels increases. Hence the same is analysed for varying number of channels and



change in Q factor and BER has been observed as shown in Fig 10 and Fig 11.

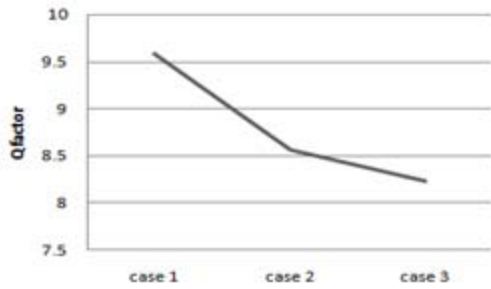

Fig. 8: Q- factor measured with unequal channel spacing

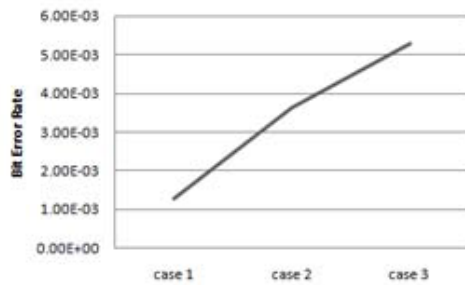

Fig. 9:BER measured with unequal channel spacing

Also much channel spacing is blocked by bandwidth constraints so channel spacing must be optimized.

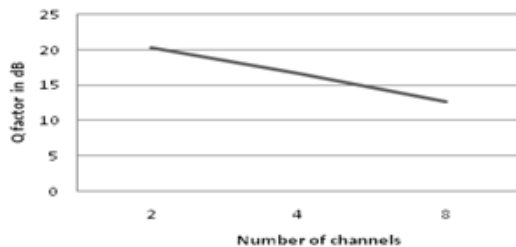

Fig. 10:Q factor Vs number of channels

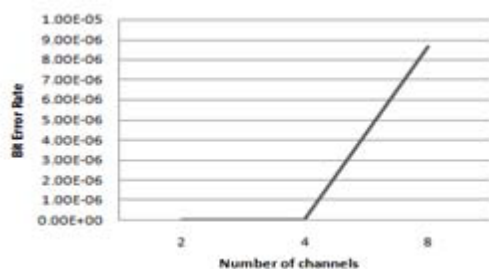

Fig. 11: Q factor Vs number of channels

VI. CONCLUSION

In this paper, the design, implementation and performance analysis of

four waves mixing in WDM optical transmission system on the basis of channel spacing and number of channels is presented. The comparison of four wave mixing effect at various values of channel spacing revealed that 95 GHz spacing has the edge over 20 GHz spacing in optical communication system. It is found that spacing of 95GHz has the lowest BER and better system performance.

Also FWM effect increases as number of channels increases. Hence, the higher spacing values between the input channels are recommended for long distance transmission without four wave mixing. It can be seen from the graphs of BER, Q-factor and eye opening that higher channel spacing gives the best performance as compared to lower channel spacing. Hence, it is concluded that higher channel spacing is best suitable to be employed in the WDM optical transmission systems minimizing the four wave mixing effect. Also further improvement in FWM effect can be achieved by unequal channel spacing. The results are in accordance with the study reported in [3,8].

In the transmission of dense wavelength division multiplexed (DWDM) signals, FWM is to be avoided, but for certain applications, it provides an effective technological basis for Fiber-optic devices. A tradeoff between advantages and disadvantages of FWM effect can be achieved by proper system design to utilize its potential to the fullest.

References

1. J.S. G. P Agarwal, "Fiber Optic communication systems", John Wiley and Sons, Inc., 1992.
2. M.Wu and W. I.Way, "Fiber nonlinearity limitations in ultra-dense WDM systems," J. Lightw Technol., Vol22, no. 6, pp. 1483–1498, Jun. 2004.
3. G. P. Agrawal, "Nonlinear Fiber Optics", 3rd ed. San Diego, CA: Academic, 2001.
4. J. Toulouse, "Optical Nonlinearities in Fibers: Review, Recent Examples, and Systems



Applications”, J. Lightw. Technol, Vol. 23, no. 11, November 2002.

5. Osamu Aso , Masateru Tadakuma and Shu Namiki , “*Four-Wave Mixing in Optical Fibers and Its Applications*”, WP Team, Opto-technology Lab., R & D Div.

6. Spector, Kai Song, MalinPremaratne, “*Effects of SPM, XPM, and Four-Wave-Mixing in L-Band EDFAs on Fiber-Optic Signal Transmission*”, IEEE Photon. Technol. Lett., Vol. 12, no. 11, pp. 1630–1632, December 2000.

7. Jianxin Ma, Jianjun Yu, Chongxiu Yu, ZhenshengJia, Xinzhu Sang, Zhen Zhou, Ting Wang, and Gee Kung Chang, “*Wavelength Conversion Based on Four- Wave Mixing in High-Nonlinear Dispersion Shifted Fiber using a Dual-Pump Configuration*”, J. Lightw. Technol, Vol. 24, no. 7, pp. 2851-2859, July 2006.

8. M.Z.Rahman, M.S.Islam, T. Rahman, S.M.A.Islam, “*Effect of chromatic dispersion on Four wave mixing in WDM Optical Transmission System*” ,International Journal on Internet and Distributed Computing Systems (IJIDCS), Vol. 1 , no.02, pp. 324-331 ,2011.

9. Nazmi A. Mohammed, Mahmoud M. Ragab, Moustafa H. Aly, “*Four wave mixing based wavelength conversion using different types of fibers*”, International Journal of Engineering Science and Technology (IJEST), Vol. 4 , no.01, pp. 324-331 January 2012

